

Capacity:
1000 Gallon Lift Station

Specifications

- Includes:
 2" Pump w/Float Switch
 2" Check Valve
 12-2 Electric Wire
 Water Resistant Box
- Optional:
 High Water Alarm

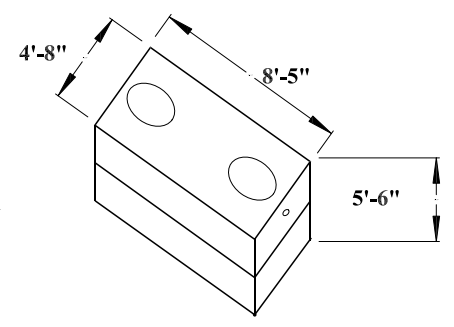

ASSEMBLED TANK

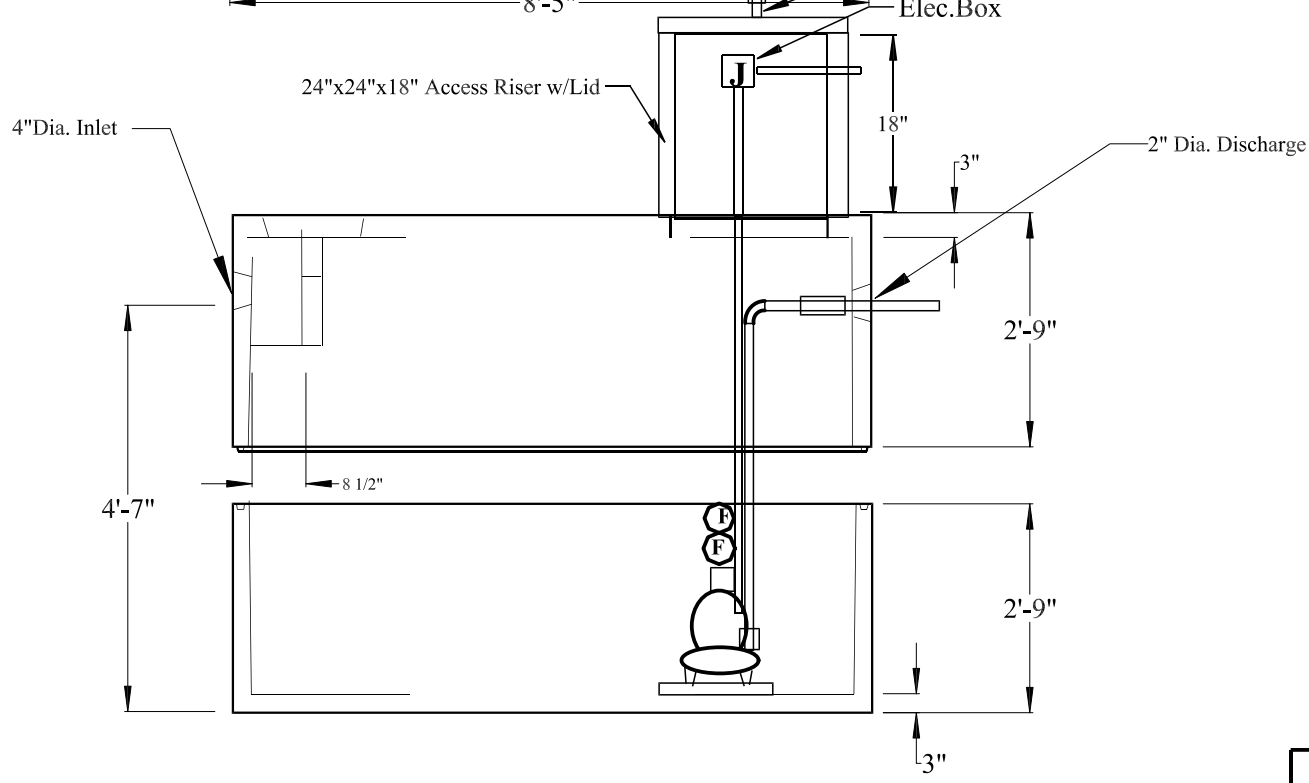

1000 Gallon Lift Station Tank

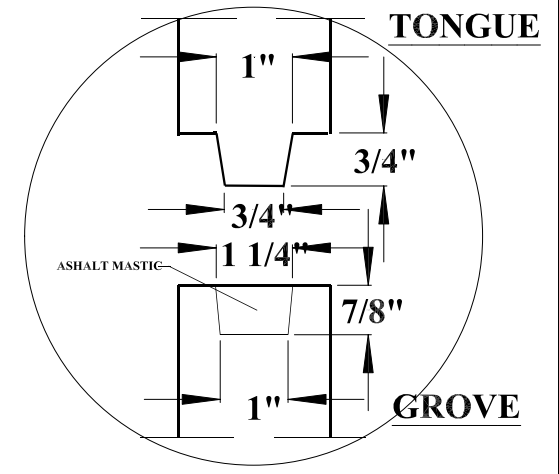

JOINT DETAIL

SCALE: NONE

COATE CONCRETE PRODUCTS	
P. O. BOX 159, WEST MILTON, OH 45383	
WEST MILTON PHONE: (937) 698-4181	
OHIO WATS PHONE: (800) 762-4066	
MODEL: 1000 GALLON TANK	
MATERIAL: VIBRATED CONCRETE REINFORCED W/ 6X6" 10/10 WIRE MESH & #3 (3/8") REBAR	
SCALE: 3/8" = 1'-0" UNLESS OTHERWISE NOTED	
DR. BY: RVA	DATE: 09/24/02
DWG. No: 01-1000SC-A01	SHEET 1 OF 1

NOTES:

DATE	REV.	LOC.	DESCRIPTION