

NOTE: 46.00 Gal / Inch

DATE	REV.	LOC.	DESCRIPTION
------	------	------	-------------

- 20" Dia. Risers w/ Lids (Cast in Place) or 24" I.D. Plastic Ultra Rib Risers & Lids (2) Required

- (1) Rebar must be 40,000 psi Strength
- (2) 6"x6" 6/6 Standard Gauge wire mesh
- (3) Concrete Strength: 5400 psi @ 28 days

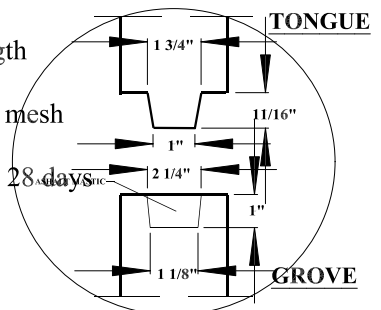

**5000 GALLON SINGLE COMPARTMENT TANK  
SEPTIC / LIFT STATION**

<b>COATE CONCRETE PRODUCTS</b>	
P. O. BOX 159, WEST MILTON, OH 45383	
WEST MILTON PHONE: (937) 698-4181	
OHIO WATS PHONE: (800) 762-4066	
<b>MODEL: 5000 GALLON LIFT TANK</b>	
<b>MATERIAL:</b> VIBRATED CONCRETE REINFORCED W/ 6X6" 6/6 WIRE MESH & #4 (1/2") REBAR	
<b>SCALE: 3/8" = 1'-0"</b> UNLESS OTHERWISE NOTED	
<b>DR. BY: RVA</b>	<b>DATE: 04/17/17</b>
<b>DWG. No: 01-5000SC-A01</b>	<b>SHEET 1 OF 1</b>